

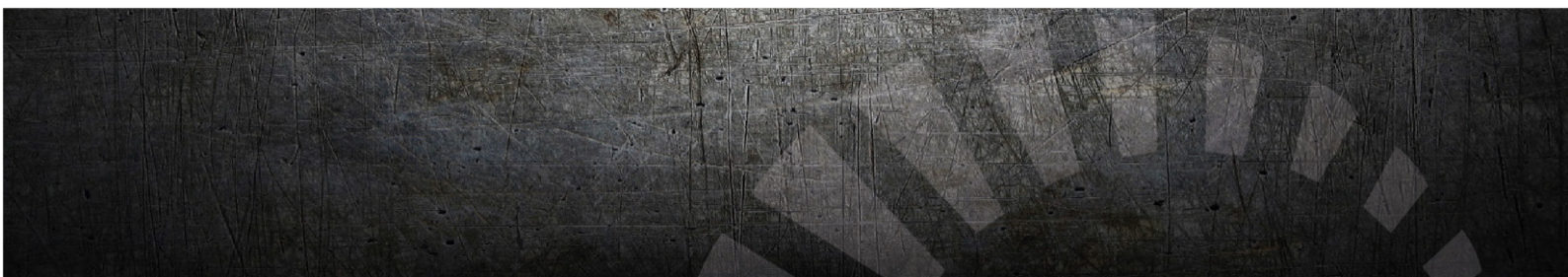

DATASHEET:

RTB HOPPER 500

PHOENIX (50 - 100 kW)

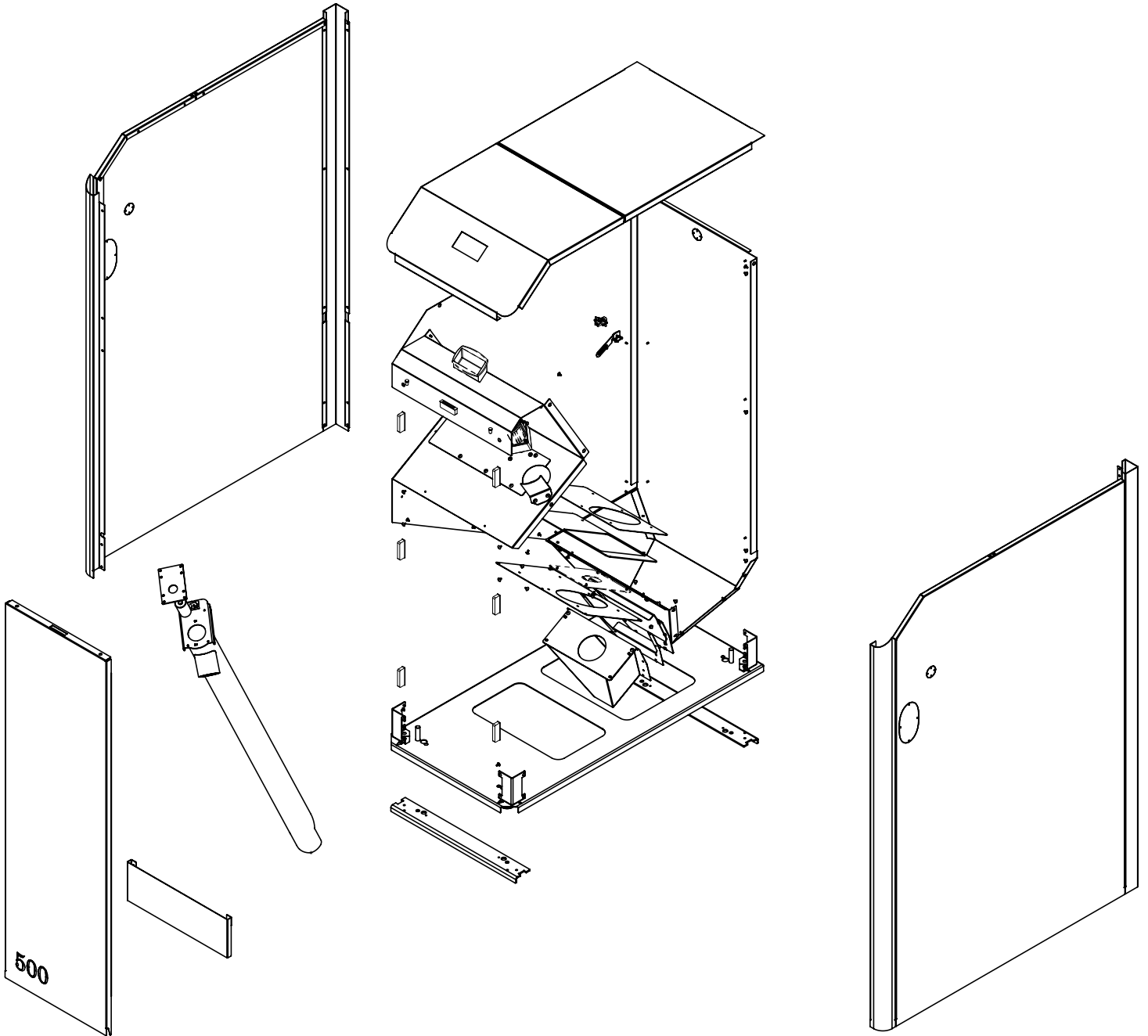



DATASHEET: RTB HOPPER 500 PHOENIX (50 - 100 kW)

Product Name	RTB Phoenix Hopper 500 (50-100kW)
SKU	901225
Compatible w/	RTB 50 Phoenix RTB 80 Phoenix RTB 100 Phoenix
Estimated Capacity (kgs)	230
Capacity (l)	350
Width (mm)	500
Depth (mm)	1000
Height (mm)	1448
Height w/ lid open (mm)	1915
Weight (kgs)	89

