

KOMPRESSORRENS MONTERING

V7 & V10 12 POLET STIK



Tilslutning motor print
MAGN/GRATE/COMP



Tilslutning på
GAMMELT print



Tilslutning på
NYT print

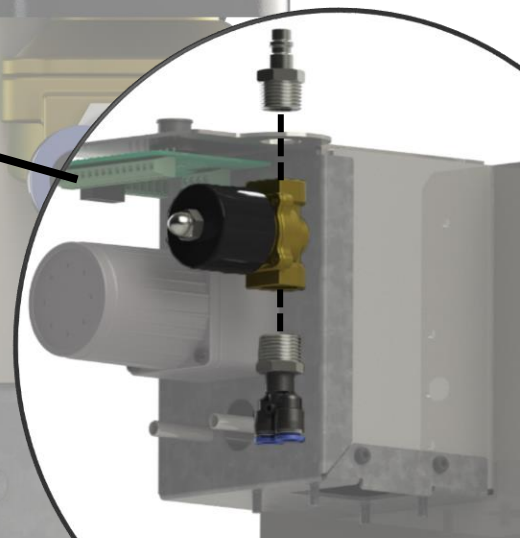
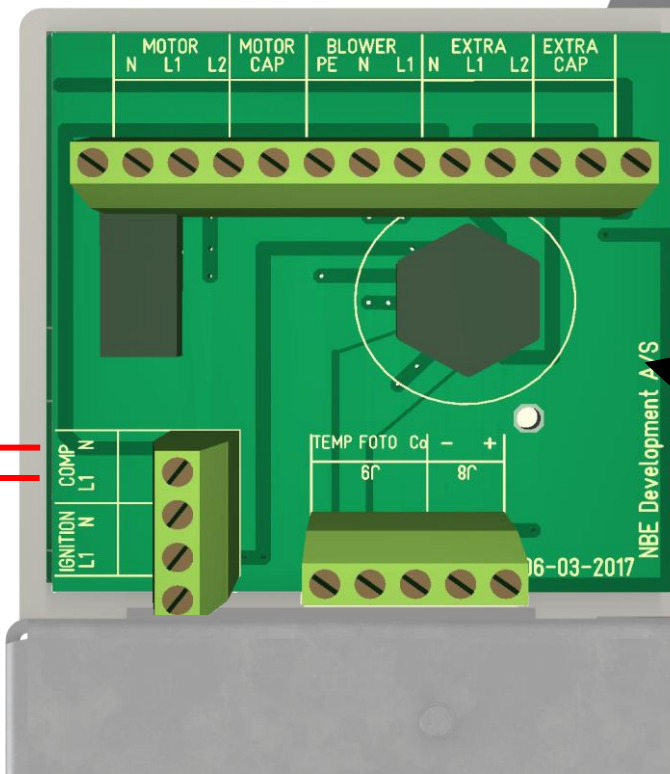
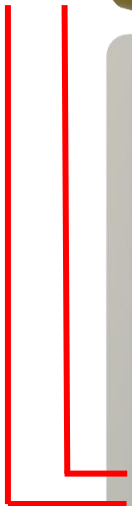

KOMPRESSORRENS MONTERING

V7 & V10 12 POLET STIK



Montering på brænder:

1. Fjern de 2 stk. 8 mm gummi propper bag på brænderen. **(Billede 1)**
2. Monter rørene inde fra brænderen, de skubbes helt ind til udkravningen på rørene stopper dem. **(Billede 2)**
3. Afkort rørene så de er 30 mm fra bagpladen **(Billede 3)**
4. Lås rørene med fjederskiven. **(Billede 4)**
5. Monter fittings og pvc-slange til magnetventil og rør. **(Billede 5 og 6)**

Justering i styring:

1. Aktiver udgangen i styringen, L6
2. Juster hvor tit der skal renses med kompressor under:
(Kompressor kg) Typisk mellem 10-50 kg
3. Juster åbnings tiden for magnetventilen
(Kompressor tid) Typisk mellem 0,5 og 2 sekunder
4. Juster ventetiden for kompressorrens
(Kompressor vent.) Typisk mellem 180.500 sekunder
så træpillerne er afbrændte, inden kompressorrens.



Billede 1



Billede 2



Billede 3



Billede 4



Billede 5



Billede 6