

UK



NBE

# PELVAC MANUAL

Version 2.000001

RTB - Ready To Burn



# CONTENTS:

Dear Customer,

Thank you for purchasing this NBE product which is designed and manufactured to the highest standards in the EU. In order for you to get the most out of your product, we strongly recommend that you carefully read this manual prior to installation and operation. In the event that you encounter any difficulties during installation or operation, we recommend that you first refer to this manual or the information provided in the support section on [www.nbe.dk](http://www.nbe.dk) or [www.nbe-global.com](http://www.nbe-global.com).

## **1. DESCRIPTION**

- 1.1 Contents
- 1.2 Pellet Storage
- 1.3 Pellet Fines
- 1.4 Dust
- 1.5 Wood Pellets
- 1.6 Electrical Consumption
- 1.7 Extraction Auger

## **2. TECHNICAL DATA**

- 2.1 Exploded View
- 2.2 Technical Data
- 2.3 Print Board Diagram

## **3. INSTALLATION**

- 3.1 Pellet Storage
- 3.2 Cloth Silo

## **4. CONTROLLER**

- 4.1 Transport
- 4.2 Timing
- 4.3 Consumption
- 4.4 Miscellaneous
- 4.5 Log

## **5. FAQ**

## **6. TROUBLESHOOTING**

## **7. DANGERS AND RISKS**

## **8. CE MARK**

## **9. PRODUCER**



# 1. DESCRIPTION:

With a **PELVAC** system you are able to transport pellets around corners, through walls, and at distances up to 15 meters. In short, you can transport your pellets in a multitude of ways that are difficult or impossible with auger conveyance.

## **1.1 Contents:**

PELVAC contains the following:

- Vacuum unit with controller, cyclone, 'air locking' rotary valve, and capacitive sensor
- 2.0 m Extraction Auger.
- 2.5 m Vacuum Hose.
- Wall Mount for Vacuum Unit

## **1.2 Pellet Storage:**

If constructing your own pellet storage tank, make sure the sides of the tank are greater than 45 degrees.

## **1.3 Wood Pellet Fines:**

Wood pellet fines can be a big problem. Fines prevents the pellets from moving easily and; therefore, increases the risk that a wood pellet bridge or mound is created along the sides of the the extraction auger opening. This prevents the pellets from dropping down easily into the spiral. In contrast, good wood pellets, with minimal fines, will roll down easily to the auger.

## **1.4 Dust:**

Moving pellets with a vacuum is naturally noisy; however, you can minimize the impact of this noise by for example setting the timer to run during the day while you are at work, and eliminate running the system during the evening.

## **1.5 Wood pellets:**

PELVAC can handle woode pellets with max 35mm length, 8mm diameter, and with a max fines percentage of 1%.

## **1.6 Electrical Consumption:**

PELVAC uses approximately 10 kWh / ton vacuum transported.

## **1.7 Extraction Auger:**

The extraction auger is built with an electric motor that rotates the spiral ensuring a controlled flow of pellets that minimizes pipe blockage.



# 2. TECHNICAL DATA:

## 2.1 Technical data

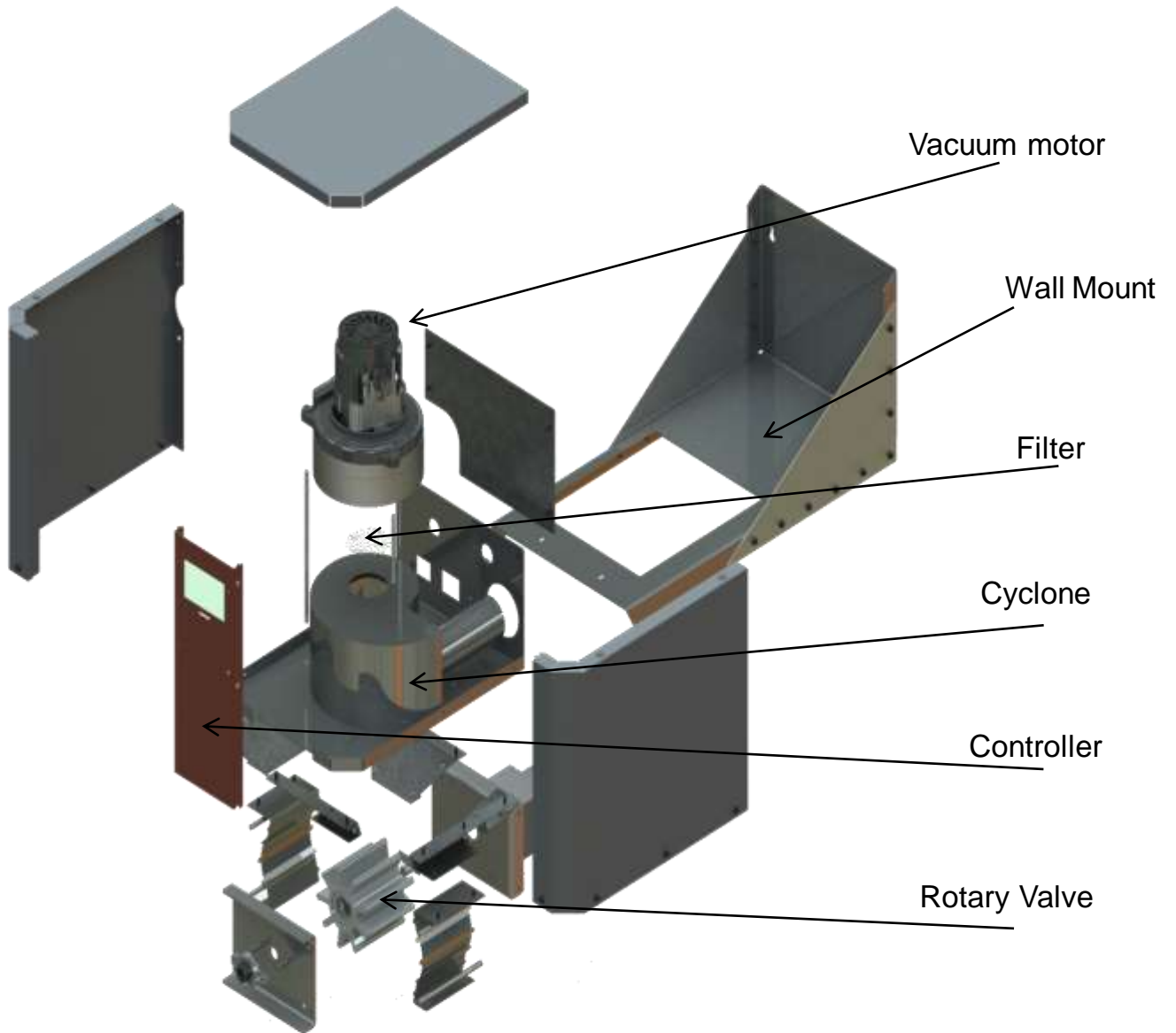

# 2. TECHNICAL DATA:

## 2.2 Technical data

	Standard
Vacuum motor	600w
Rotary valve motor	20w
Hose diameter	50mm
Max ceiling height	2,5m
Max. Transport range with smooth pipes.	15m
Capacity	60 kg/hour
Noise level:	70dB
Connection VAC / Hz	230/50
Extraction auger motor	60w
Electrical Consumption/ ton	10kW
Max. Wood pellet length	35mm
Max. Wood pellet diameter	8mm
Max. wood pelet fines	1%

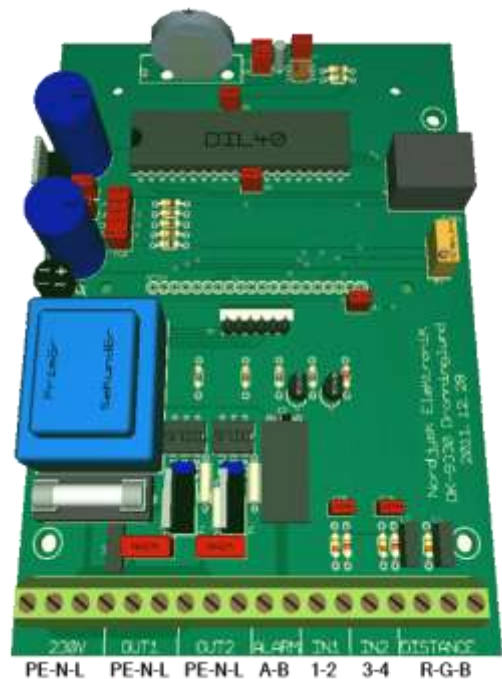

## 2.3 Print diagram

EQUIPMENT	INPUT / OUTPUT	CONNECTION
Supply	230V	PE / N / L
Vacuum	OUT1	PE / N / L
Extraction Auger	OUT2	PE / N / L
Alarm	ALARM	A / B
Contact Cyclone	IN1	1 / 2
Do not use	IN2	3 / 4
Distance Sensor	DISTANCE	Rød / Grøn / Blå

# 3. INSTALLATION:

## 3.1 Installation in V-bottom

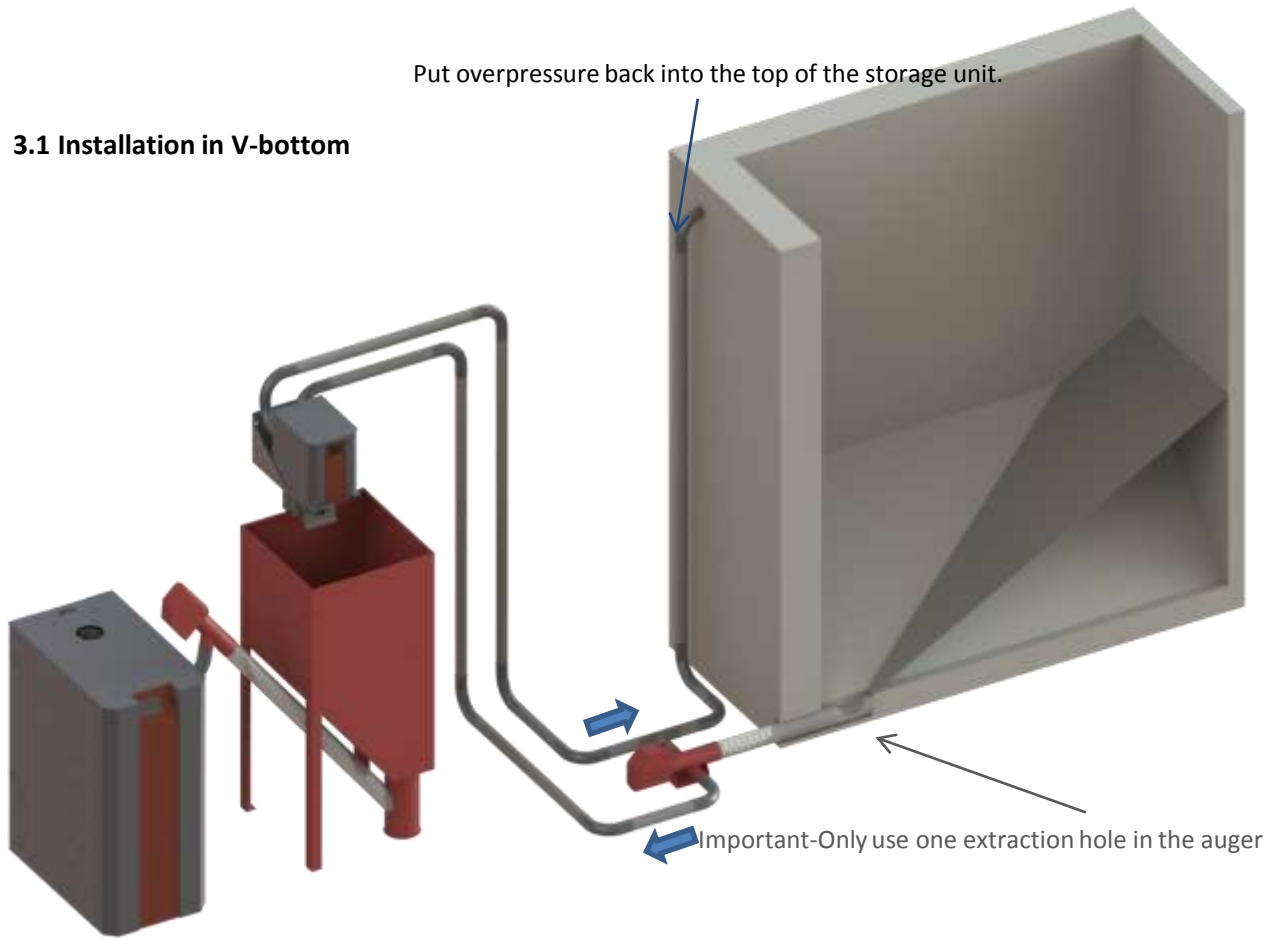

## 3.2 Installation Clothe Silo

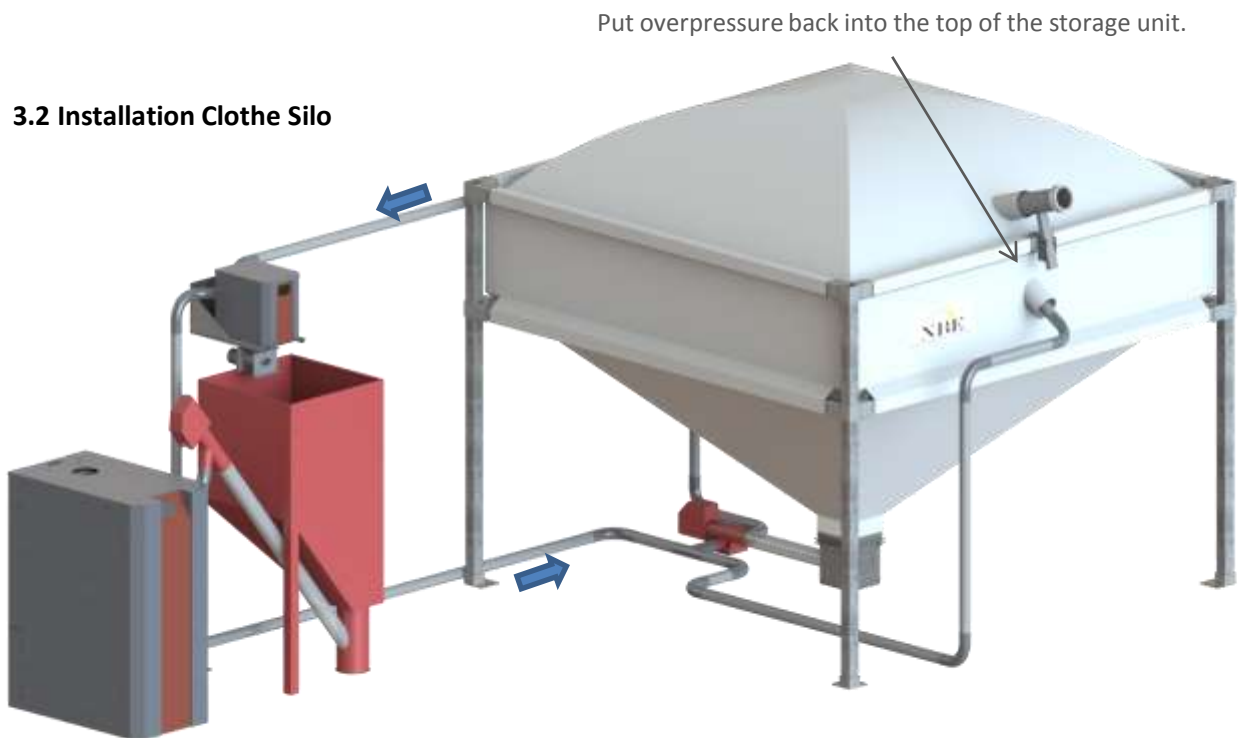

# 4. CONTROLLER:

## 4.1 Transport:

MAIN MENU  
**TRANSPORT**  
 TIMING  
 CONSUMPT.  
 VARIOUS  
 LOG  
 MANUAL

<b>TRANSPORT</b>	
Driving Time	5 min
Overrun Time (Vac)	10 sec
Pause Time	10 sec
Start Delay	5 min
Por. After Alarm 2	
Dutycycle Auger 70 %	
Distance Start	70 cm
Distance Stop	20cm
Use Distance (sensor)	NEJ
Cap. Sensortype	N/O

ON/OFF      UP/DOWN  
 RESET / ALARM      MENU



- Driving Time:** Specify the running time of the vacuum system. Driving Time can be adjusted to fit any hopper size. *Note: Test and adjust Driving Time as high as possible without over filling the hopper.*
- Overrun Time (Vac):** Specify the time in seconds the extraction auger should stop prior to the vacuum stopping during a vacuum cycle. *Note: Prevents pellet blockage in the pipes by allowing the vacuum to clear out any remaining pellets in the piping system.*
- Pause Time:** Specify pause time between filling cycles. Important when controlling filling cycles via a distance sensor as the pause will allow the pellets to settle in place prior to taking a new distance sensor reading and initiating another vacuum cycle. (*Note: When USE Distance is not activated, Pause Time will be ignored.*)
- Start Delay:** Time delay before starting a vacuum cycle. This delay is to ensure that there is truly a call for pellets from the capacitive sensor; thus, preventing overfeeding of the hopper.
- Por. After Alarm:** Portions(Por.) after alarm refers to the number cycle portions the vacuum system will run after the vacuum has gone through a no pellets alarm. Therefore, insert the number of cycles desired that would fill up the hopper when empty.
- Dutycycle Auger:** Specify the % running time of the extraction auger. *Note: increasing duty cycle auger % may lead to over feeding of the rotary valve in the vacuum unit and cause a pellet jam. If a jam occurs in the vacuum unit's rotary valve, reduce duty cycle auger %.*
- Distance Start:** Starts the system up when the distance sensor measure under this value.
- Distance Stop:** Stops the system when the distance sensor measures over this value.
- Use Distance (sensor):** Activates the distance sensor. Only activate if a distance sensor is installed (optional)
- Cap. Sensortype:** Specify if the capacitive sensor is normally open or normally closed.

# 4. CONTROLLER:

## 4.2 Timing:

MAIN MENU  
TRANSPORT  
TIMING  
CONSUMPT.  
VARIOUS  
LOG  
MANUAL

TIMING	
MO-FR Start 1	12.05
MO-FR Start 2	OFF
MO-FR Start 3	OFF
SA-SU Start 1	OFF
SA-SU Start 2	OFF
SET CLOCK	9.35
SET WEEKDAY	Sat
SET DATE	25
SET MONTH	2
SET YEAR	15

### MA-FR Start 1-3:

Specify when the vacuum system should run. You can choose up to 3 periods during the day, M- Fr. The system will run until the hopper is full i.e when the capacitive sensor or distance sensor registers that the hopper is full.

### SA-SU start 1-2

Specify when the vacuum system should run. You can choose up to 3 periods during the day, Sa- Su. The system will run until the hopper is full i.e when the capacitive sensor or distance sensor registers that the hopper is full.

### Set Clock:

Specify the time.

### Set Weekday:

Specify the current day of the week.

### Set Date:

Specify the date.

### Set Month:

Specify the month.

### Set Year:

Specify the year.



# 4. CONTROLLER:

## 4.3 Consumption:

MAIN MENU  
TRANSPORT  
TIMING  
CONSUMPT.  
VARIOUS  
LOG  
MANUAL

Consumpt.	
Number Cycles	1950
Reset Cycles	No
Consumpt (kWh)	34,5
Reset Consumpt.	NO
Hours Vacuum	35

**Number of Cycles:** Displays the number of times the system has cycled.

**Reset Cycles:** Resets the counter for the number of cycles performed

**Consumpt.( kWh):** Displays how many kWh of electricity the system has used.

**Reset kWh:** Resets the kWh counter.

**Hours Vacuum:** Displays the number of hours of operation.  
( *Expected vacuum motor lifetime is about 500hrs.*  )

## 4.4 Various:

MAIN MENU  
TRANSPORT  
TIMING  
CONSUMPT.  
VARIOUS  
LOG  
MANUAL

Various	
Language	ENG
Power Auger	60w
Power Vacuum	650W
Distance Cal.	0 cm

**Language:** Choose language.

**Power Auger:** Shows the consumption of the auger (W).

**Power Vacuum:** Shows the consumption of the vacuum (W).

**Distance Cal. :** Shows calibration of the distance sensor if one is specified.

# 4. CONTROLLER:

## 4.5 LOG:

MAIN MENU  
TRANSPORT  
TIMING  
CONSUMPT.  
VARIOUS  
LOG  
MANUAL

LOG		
1 MON	05.34	RUN
2 MON	03.55	RUN
3 SUN	22.45	RUN
4 SUN	21.34	RUN
5 SAT	23.55	RUN
6 SAT	20.12	RUN

**LOG:** The last 50 events are logged here.

## 4.6 Manual:

MAIN MENU  
TRANSPORT  
TIMING  
CONSUMPT.  
VARIOUS  
LOG  
MANUAL

**Activate Auger:** Activates extraction auger motor manually. For example, use to test function.

**Activate Vacuum:** Activates vacuum motor manually. For example, use to test function.

**Timeout:** Output will automatically turn off after 2 minutes of running.



# 5. FAQ:

## **Is the PELVAC system noisy ?**

Yes, transporting pellets via a vacuum system is noisy; however, you are able to use the timer function in the controller to have it run during work hours or prevent the system from running during unwanted hours; such as during the evening.

## **Is the PELVAC system dusty?**

The PELVAC system is a closed loop system; however, part of the over pressure in the air return is redirected back to the silo. If your silo is not completely air tight or does not consist of breatheable dust reducing fabric, then some dust can escape.

## **What is the max distance you can transport pellets?**

Max distance is up to 15 meters when installing the system with smooth vacuum tubes and when vertical suctions are minimized below 2.5 meters.

## **What is the max vertical suction height?**

A lot of suction is required to transport pellets vertically and should be minimized as much as possible; however, it should not be a problem to perform vertical lifts of up to 2.5 meters.

If you require more suction power, consider upgrading to a 1000 watt vacuum motor that will give you 30% more power.

## **How often should you clean the vacuum filter?**

It depends. Normally it is not needed to clean the filter as the filter is designed only to prevent large fines from passing through, but all wood pellets are different and some can cause blockages more easily than others. If you are repeatedly having pressure loss in the vacuum you may want to begin a regular cleaning schedule of the filter to prevent downtime.

## **How often should you change the vacuum motor?**

Typical lifetime of the motor is 500 hours ( about 30 tons of pellets ) and should be replaced. However, with the price of a new vacuum motor around 60 euros, it still remains as a very inexpensive solution.

## **Will dust in the pellets be a problem?**

Pellets with less than 1% dust, typically, do not pose any problems.

## **Can I run the system without a filter in the cyclone?**

No! The metal filter protects the vacuum from pellets. Wood pellets that are sucked into the vacuum will damage the vacuum motor.

## **How does the distance sensor work?**

Distance sensors work by ultrasound. One part of the sensor resonates a ultra sound wave which echos back from the pellet level; while the other sensor measure the time for the echoing. This allows the controller to calculate distance.

## **Where can I purchase smooth vacuum pipes?**

Contact your NBE dealer.

## **Where can I purchase the pipe bends for the 50mm pipes?**

These fittings are common at any home building or plumbing store.



# 6. TROUBLESHOOTING:

## **Wood pellets are jamming the rotary valve in the vacuum unit.**

1. Turn down the **Durtycycle %** under Menu **TRANSPORT**. This will prevent the rotary valve from over filling.
2. Make sure that your wood pellets are no longer than 35mm.

## **There is not enough suction.**

1. Check that all the connections are tight.
2. Check the filter for any build up of dust.
3. Check that the running time is not too long; which can over fill the cyclone with pellets.
4. Check that the vertical lift height is no taller than 3.5 meters.
5. Check that the transport distance is no more than 15 meters.
6. Check that all pipes are of the same dimension.

## **There is no power to the system.**

1. Make sure that there is power on the contact.
2. Check to see if the fuse ( 7A ) is functional. Replace if necessary.

## **The extraction auger cannot empty the silo.**

1. Check that the sides of the silo are greater than 45 degrees.
2. Make sure that there is no more than 1% dust in the pellets.



# 7. DANGERS AND RISKS



Never touch or handle the auger when the system is powered. There will be no warning when the system starts.



The system is provided with an electric current of 230V / 50Hz. An incorrect installation or improper repair can cause life-threatening electric shock. Electrical connection must be performed by the person who has the right skills and competences. Performing electrical installation must be performed in respect to the current local rules. Always disconnect the system from the power supply before starting maintenance work and servicing. The system must be connected to a separate electrical circuit, which is equipped with the proper circuit breaker and residual current device.



Never climb into a pellet silo without proper ventilation. Enough wood gas can be toxic and even deadly.



Always read the manual prior to installing and repairing the system. If necessary, seek out professional help.



The system may only be serviced by knowledgeable professionals. If you are in doubt about the safe operations and use of this equipment, please contact your dealer.



# 8. CE MARK

NBE hereby confirms, that this product has been produced in accordance with:

Low Voltage Directive	2006/95/EC
Electromagnetic Compatibility Directive	2004/108/EC
Machine Directive	2009/125/CE



This symbol indicated on the product confirms that the product has been produced in accordance with the above directives.

## 9. Producer:

**NBE Production A/S**  
**Kjeldgaardsvej 2**  
**9300 Sæby**  
**DENMARK**  
**0045-88209230**  
[www.nbe.dk](http://www.nbe.dk)  
[www.nbe-global.com](http://www.nbe-global.com)



# NBE

PRODUCTION A/S  
Kjeldgaardsvej 2  
9300 SÆBY  
Tlf. 8820 9230  
CVR nr. 34 89 03 23  
[www.nbe.dk](http://www.nbe.dk)

